

LYNK+

USER MANUAL
RTX 5090 UPGRADE KIT

PLEASE READ BEFORE STARTING:

Congratulations on your new **LYNK+ liquid cooling system**.

The **modular design** of **LYNK+** makes installation quick and simple, letting you enjoy top performance in **just a few steps**.

IF YOU PURCHASED A **LYNK+ UPGRADE KIT**, PLEASE FOLLOW THE INSTALLATION STEPS BELOW TO MOUNT THE **LYNK+ COOLER MODULE** ONTO YOUR GRAPHICS CARD.

IF YOU PURCHASED A **GRAPHICS CARD WITH A PRE-INSTALLED LYNK+ COOLER** YOU CAN START FROM HERE: **INSTALLING THE LYNK+ RADIATOR MODULE**

STEP 1: COMPATIBILITY

Even though the system is designed with maximum possible **compatibility** in mind, there are some things that need to be **taken into consideration**:

FOR A FULL COMPATIBILITY GUIDE WITH EVERYTHING YOU NEED TO KNOW WHEN PLANING A NEW PC WITH LYNK+ CLICK HERE: [LYNK+ COMPATIBILITY](#)

STEP 2: SPECIAL INSTRUCTIONS FOR THERMAL PADS

The **thermal pads** bundled with your **LYNK+ cooler** provide **high thermal conductivity**. This requires them to be **softer** and more malleable **than usual**.



DON'T OVERSTRECH THE THERMAL PADS DURING INSTALLATION

FOR AN INSTRUCTION VIDEO ON HOW TO BEST HANDLE THE PADS AND AVOID DEFORMATION CLICK HERE: [THERMAL PAD INSTALLATION VIDEO](#)

STEP 3: INSTALLATION INSTRUCTIONS

If you've completed the steps above, please **continue to the next pages** for a complete **User Manual** on how to install your LYNK+ system.

TABLE OF CONTENTS LYNK+ USER MANUAL

INSTALLING THE LYNK+ GPU COOLER MODULE..... 5

INSTALLING THE PLATE KIT 12

INSTALLING THE LYNK+ RADIATOR MODULE 15

CONNECT BOTH MODULES USING THE LYNK+ QUICK CONNECT 21

INSTALLING LYNK+ GPU..... 22

CONFIGURING THE FANS 23

TROUBLESHOOTING & LED BLINK CODES 28

INSTALLING THE LYNK+ GPU COOLER MODULE

BOX CONTENTS – RTX 5090 UPGRADE KIT COOLER

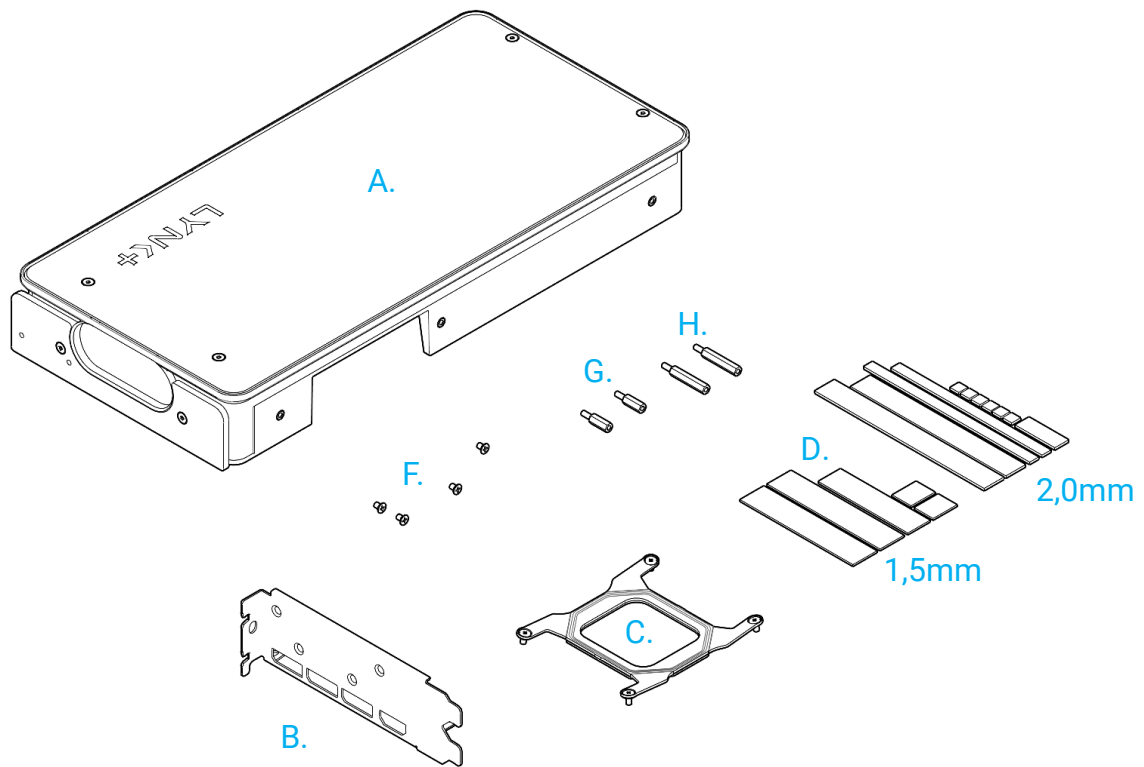

PACKAGE INCLUDES:

- A. 1x Modular RTX 5090 liquid cooler
- B. 1x 2-Slot Slot bracket: Fits all supported GPUs)
- C. 1x Spring Cross Plate: With built-in mounting hardware
- D. 1x Thermal Pad Set (1,5mm and 2,0mm Thicknesses)
- E. 1x User Manual
- F. 4x Slot Bracket Screws
- G. 3x 10mm Standoffs
- H. 2x 20mm Standoffs

DIMENSIONS – RTX 5090 UPGRADE KIT COOLER

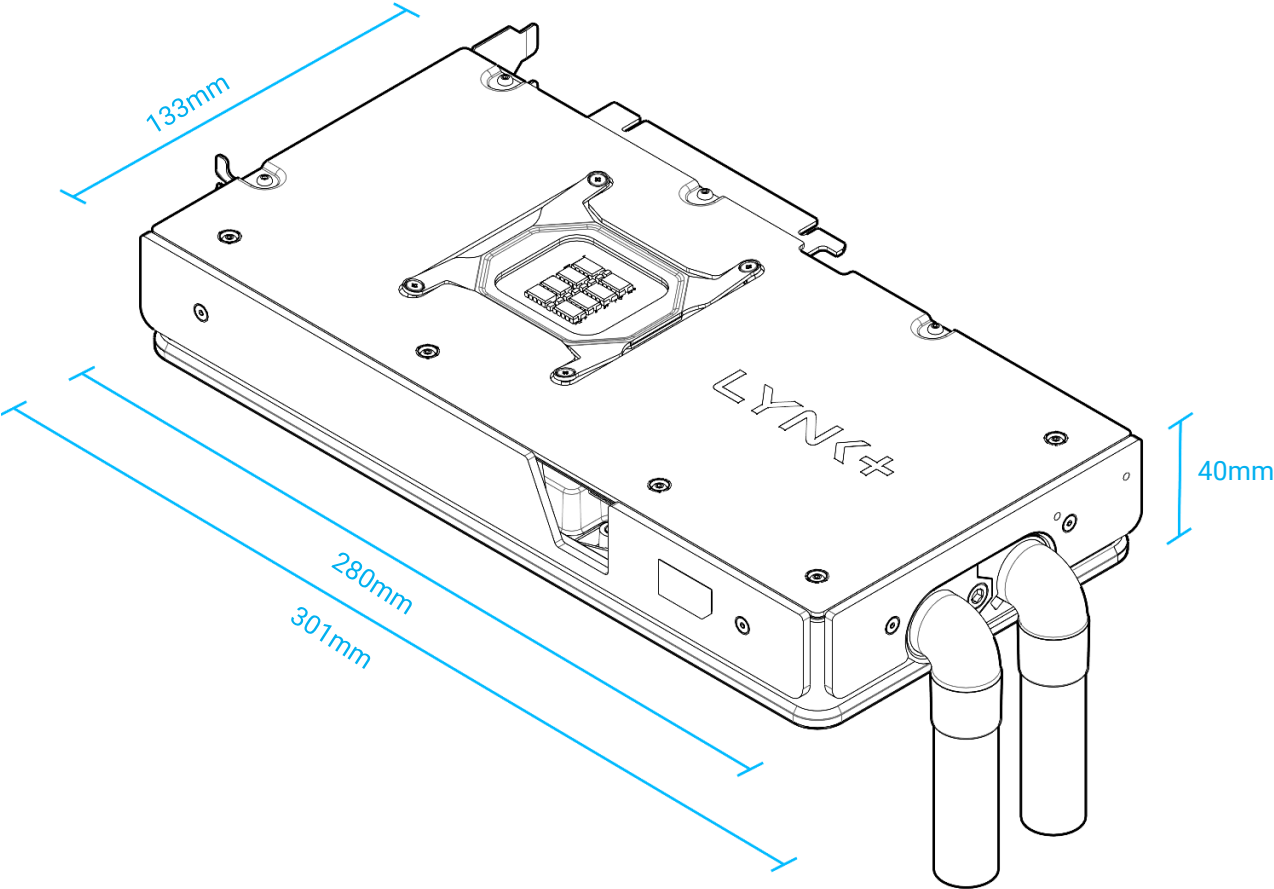

PREPARING GPU

STEP 1

Remove all screws holding the stock cooler to the GPU PCB.

STEP 2

Remove I/O bracket and spring cross.

STEP 3

Carefully unplug the fan and RGB connectors from the board.

STEP 4

Remove all thermal pads and thermal grease. Use lint-free cloth and isopropyl alcohol for cleaning.

PREPARING THE LYNK+ COOLER

STEP 5

Depending on your GPU model, install standoffs (item G and H) in indicated positions. Make sure to use the correct length of standoffs for each position.

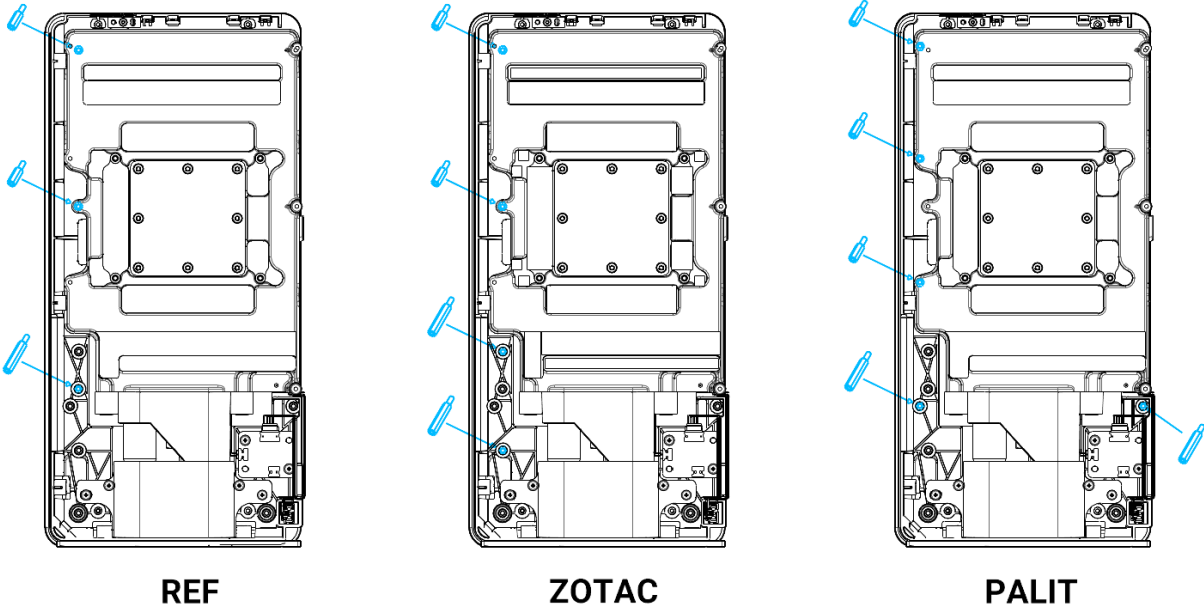

STEP 6

Remove protective foil from copper cold plate. Make sure the cooler block's surface is clean.

THERMAL PADS

THE THERMAL PADS BUNDLED WITH YOUR LYNK+ COOLER OFFER HIGH THERMAL CONDUCTIVITY. THIS REQUIRES THE PADS TO BE MALLEABLE. **MAKE SURE YOU DON'T OVERSTRECH THE PADS DURING INSTALLATION**

CLICK HERE FOR AN ISTRUCTION VIDEO ON HOW TO CORRECTLY INSTALL THE PADS [THERMAL PAD INSTALLATION VIDEO](#)

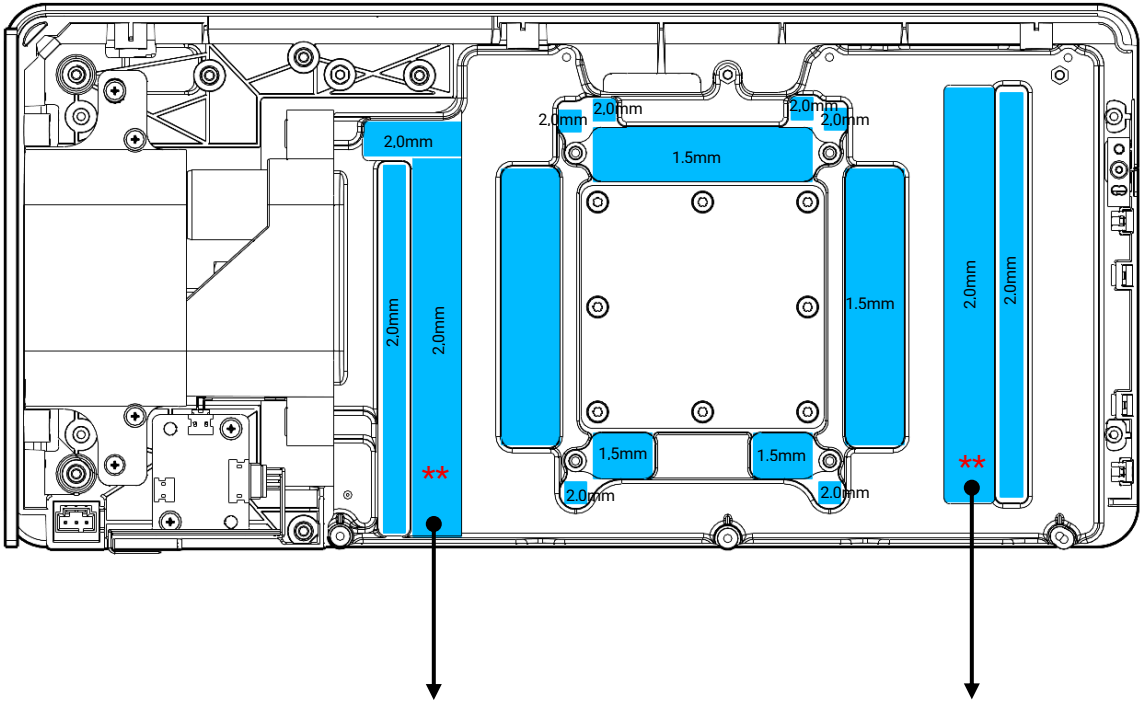

**** THE INDUCTORS ON ZOTAC GPU'S DON'T REQUIRE ADDITIONAL COOLING, INSTALLATION OF THESE TWO THERMAL PADS IS NOT NECESSARY.**

STEP 7

Apply thermal pads (item D) on indicated positions. Make sure to use the correct thickness for each position.

APPLYING THERMAL PASTE

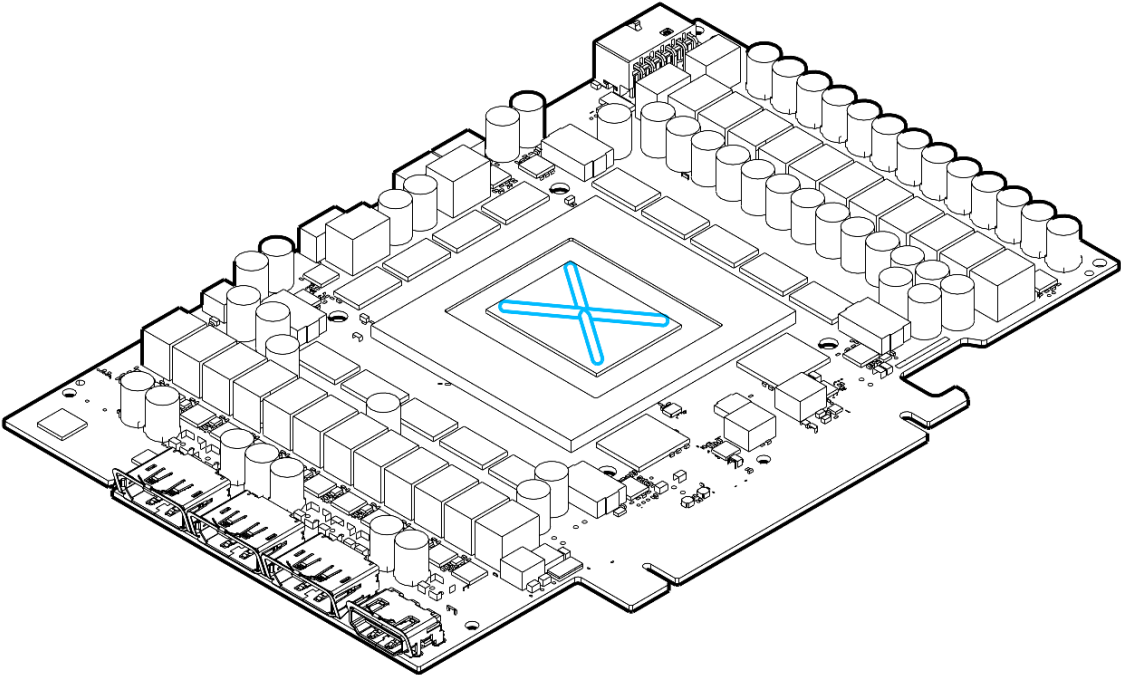

STEP 8

Evenly apply your chosen thermal paste on the GPU chip, an “X” pattern is usually good enough, but thinly spreading the paste is recommended.

ATTACHING WATERBLOCK

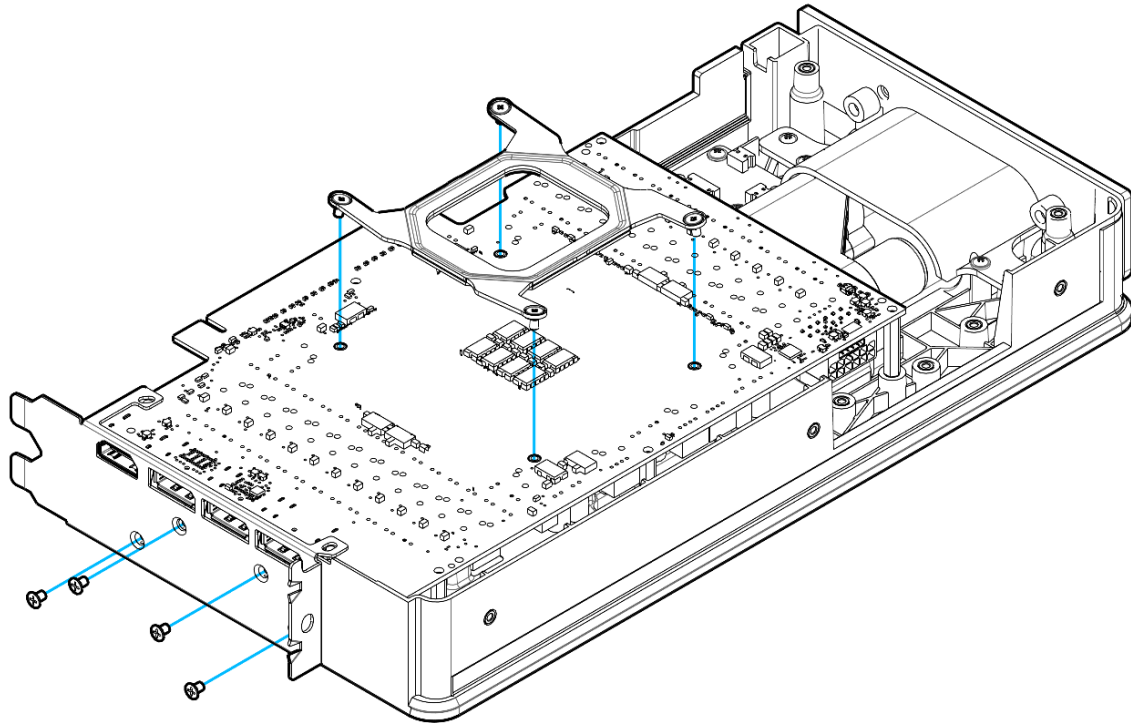

STEP 9

Place prepared GPU onto the LYNK+ Cooler with installed thermal pads and standoffs. Ensure that the mounting holes on the PCB and the cooler are aligned.

STEP 10

Position spring cross (item C), tighten screw 1 to about half its length, press down screw 2 and tighten again to about half its length. Next repeat same steps for position 3 and 4. Then gently tighten all screws until stop.

STEP 11

Position I/O bracket (item B) onto cooler and tighten using included 4 countersunk screws (item F).

INSTALLING THE PLATE KIT

USE THE MATCHING PLATE KIT FOR YOUR GRAPHICS CARD. CHECK THE [LYNK+ PLATE KIT COMPATIBILITY LIST](#)

BOX CONTENTS

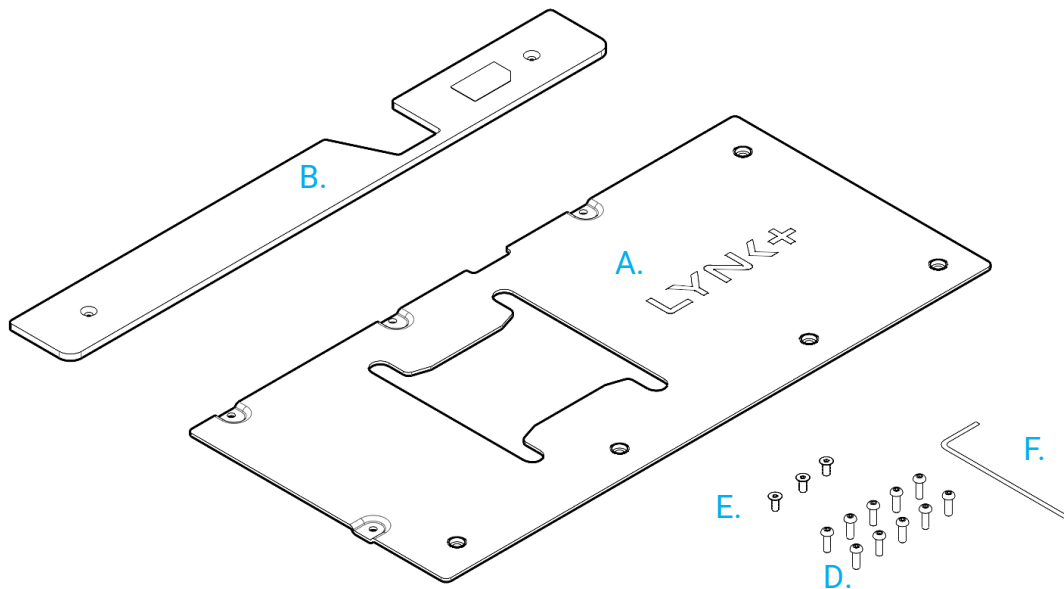

PACKAGE INCLUDES:

- A. 1x Back Plate (for Either Ref, Zotac or Palit)
- B. 1x Front Plate (for Either Ref, Zotac or Palit)
- C. 1x User Manual
- D. 10x Backplate Screws
- E. 3x Front Plate Screws
- F. 1x L-shaped key

DIMENSIONS

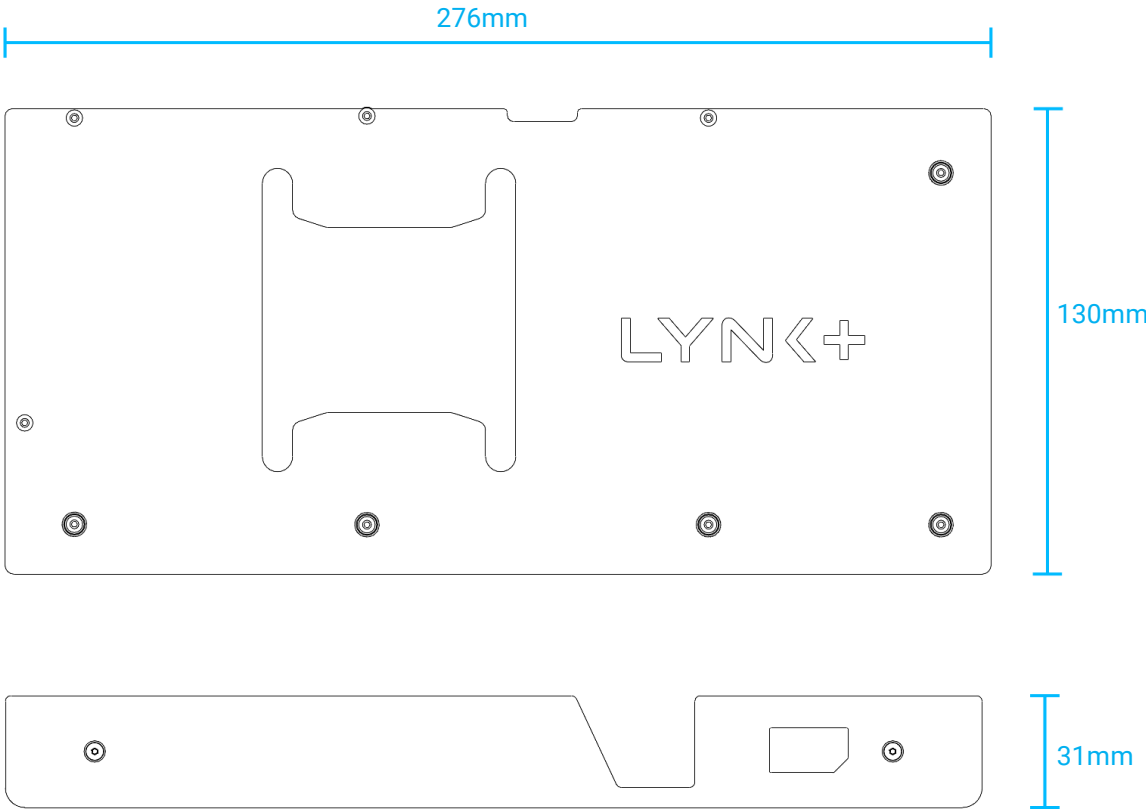

INSTALLING BACKPLATE AND FRONT PLATE

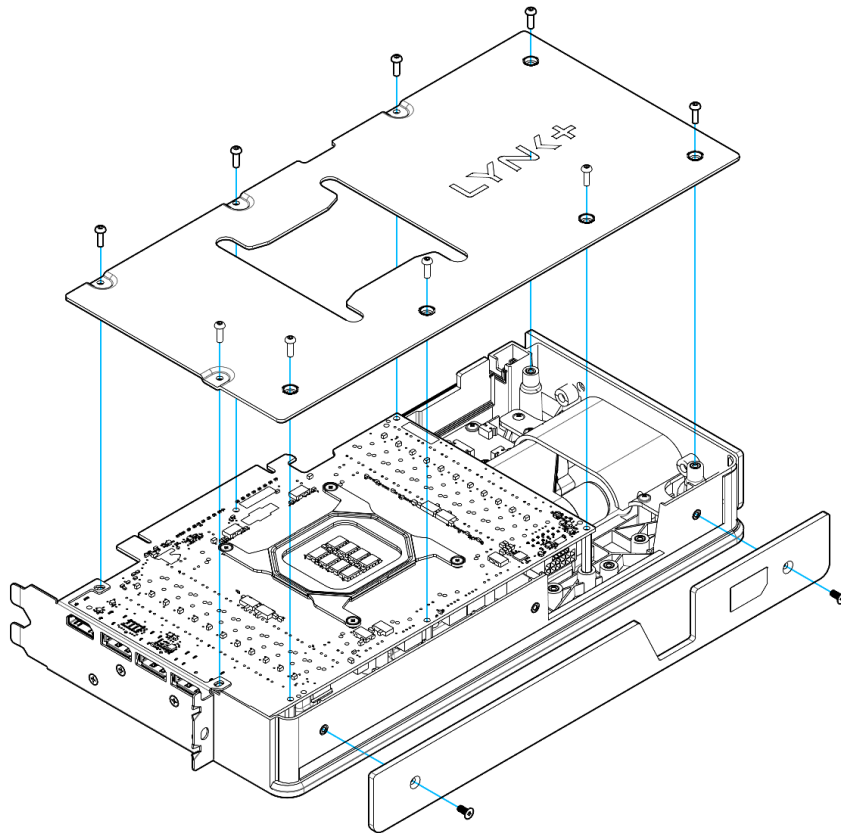

STEP 12

Make sure LED and fan cable are outside the cooler and positioned in the cable slot.

STEP 13

Place the backplate onto the GPU and make sure the screw holes are aligned. Press on I/O bracket and tighten the two bracket screws first. Install all remaining screws. Slightly fasten all screws before you tighten them.

DON'T USE EXCESSIVE FORCE WHEN TIGHTENING THE SCREWS!

STEP 14

Attach the front plate with 2 screws to the cooler front

INSTALLING THE LYNK+ RADIATOR MODULE

BOX CONTENTS

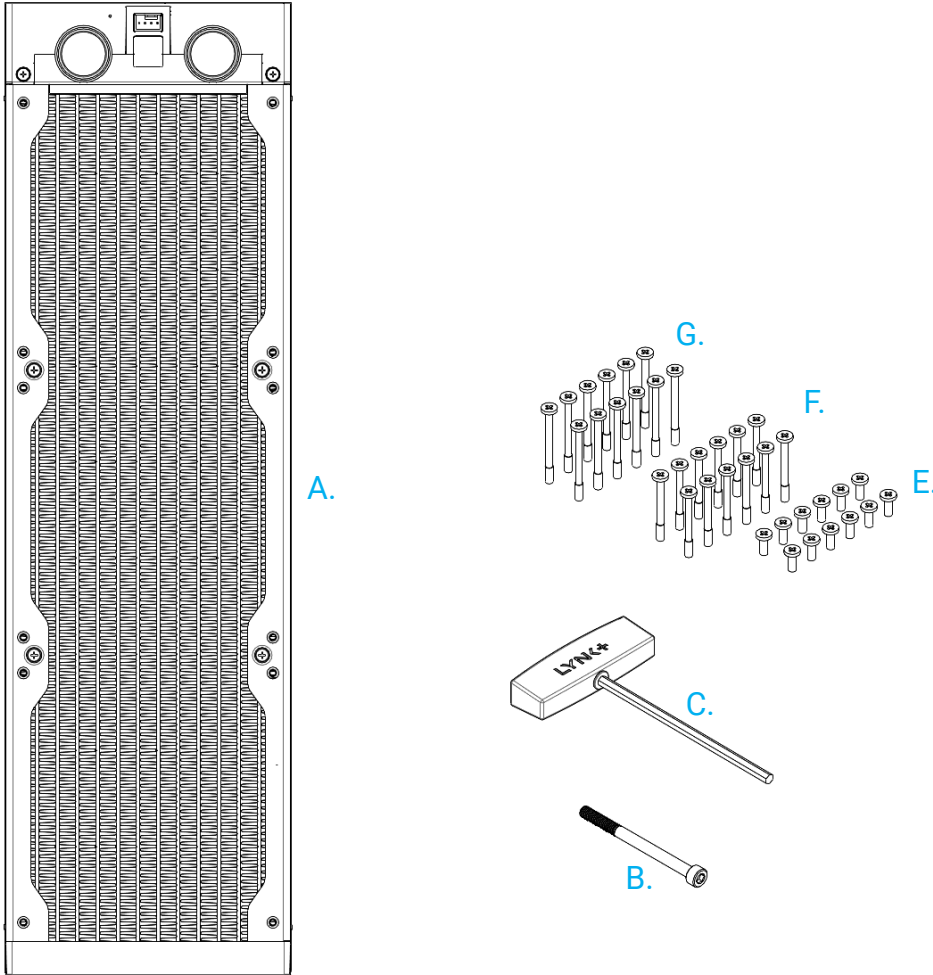

Package includes:

- A. 1x 360mm Radiator Module
- B. 1x Quick Connect Screw
- C. 1x LYNK+ Hex Key
- D. 1x User Manual QR
- E. 12x Case screws
- F. 12x Fan screws for 25mm thick fans
- G. 12x Fan screws for 30mm thick fans

DIMENSIONS

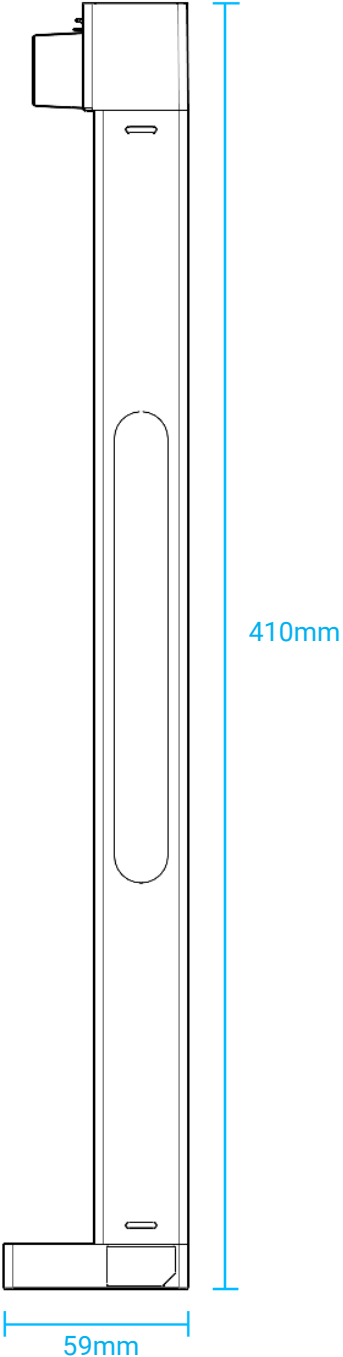
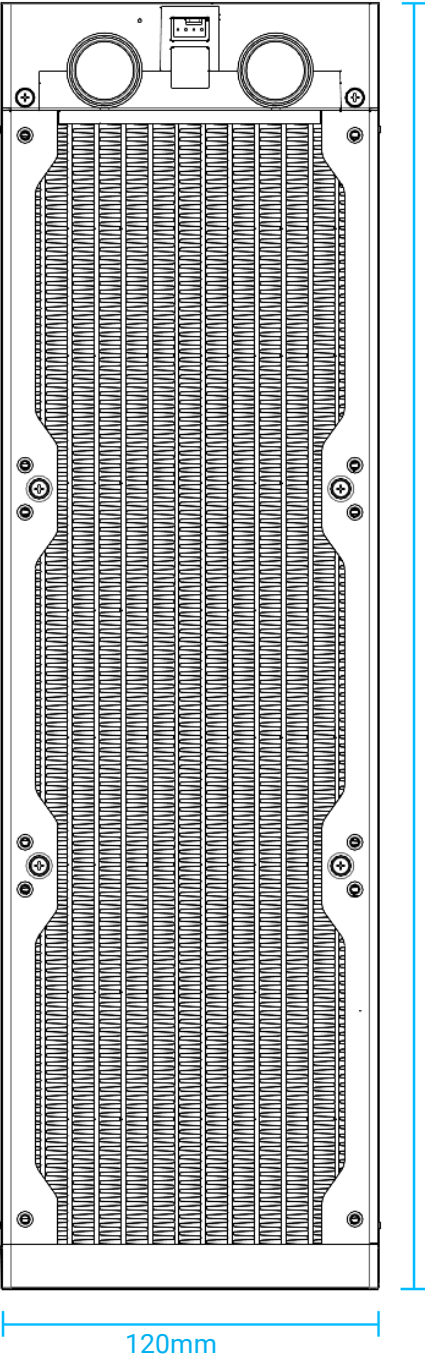

ASSEMBLY OF THE RADIATOR

THE LYNK+ RADIATOR MODULES DON'T USE ANY PROPRIETARY CONNECTIONS AND ARE COMPATIBLE WITH MULTIPLE DIFFERENT FANS, BUT DUE TO ITS SPECIAL DESIGN, SOME FANS MIGHT NOT FIT THE RADIATOR. CLICK [HERE](#) TO CHECK FAN COMPATIBILITY.

STEP 1: INSTALL FANS ON RADIATOR

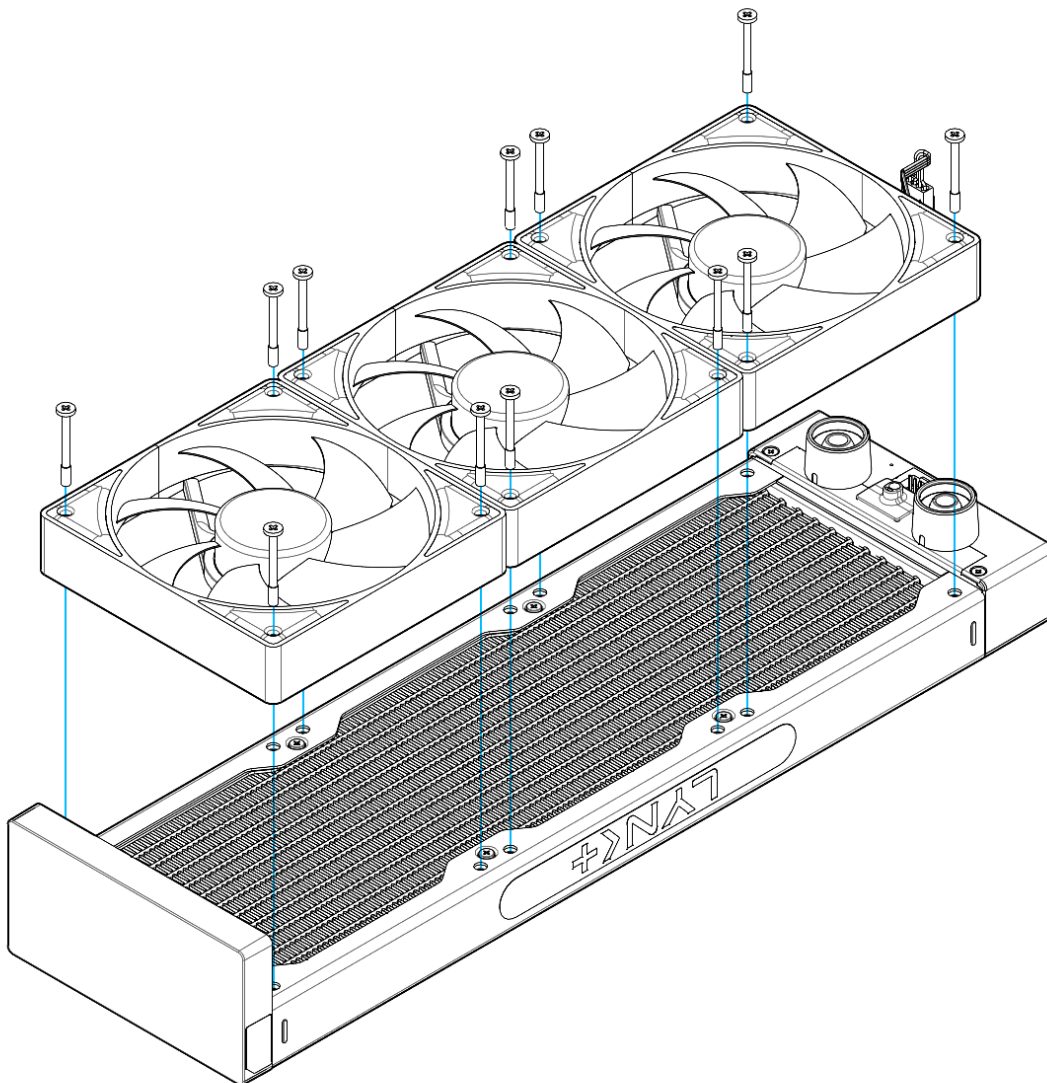

The package includes screws for 25mm and 30mm thick fans. Pick the ones that better fit your chosen fans. Screw the fans onto the radiator.

STEP 15: CONNECT FANS TO RADIATOR

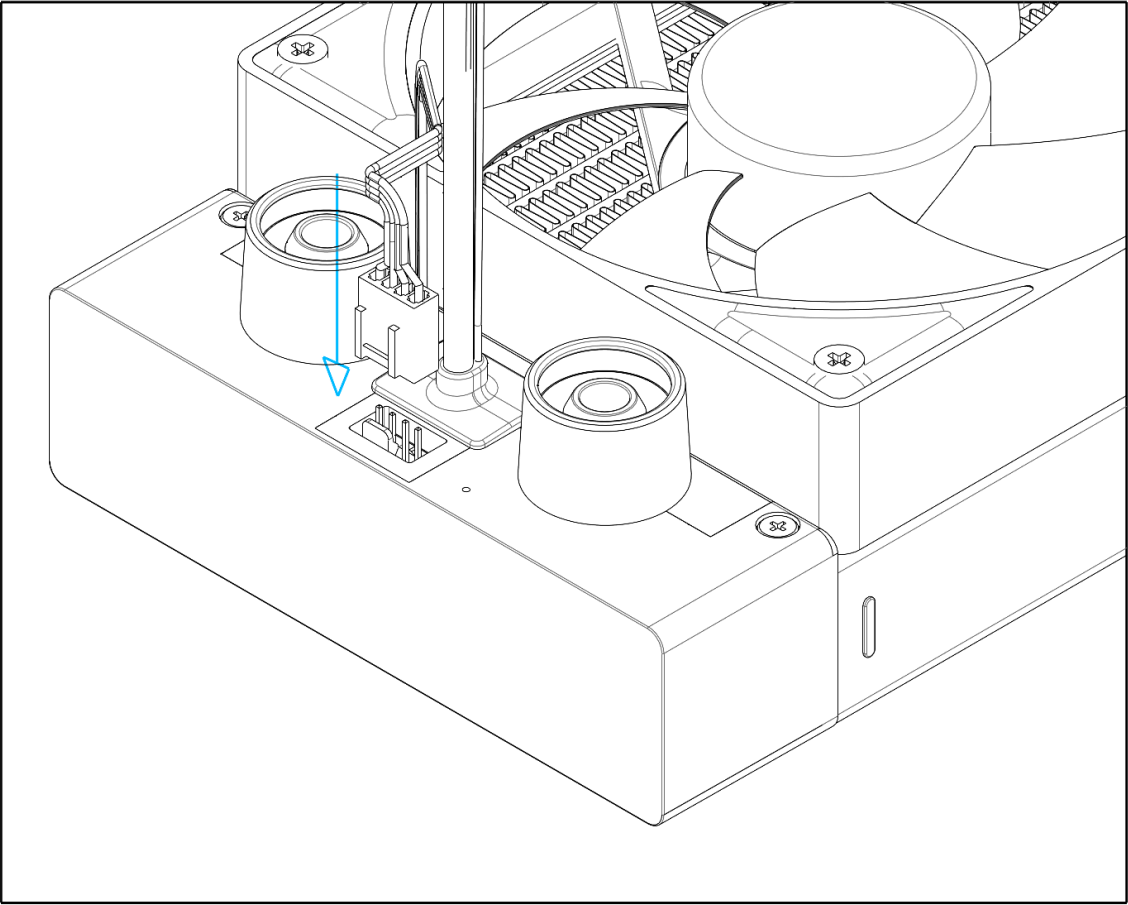

Connect all 3 fans as daisy-chain using Y splitting cables, and the first one to the radiator front 4-Pin PWM connector between the tubes. The Radiator Module will provide power and RPM requirement to the fans connected to it.

STEP 16: INSTALL RADIATOR ON PC CASE

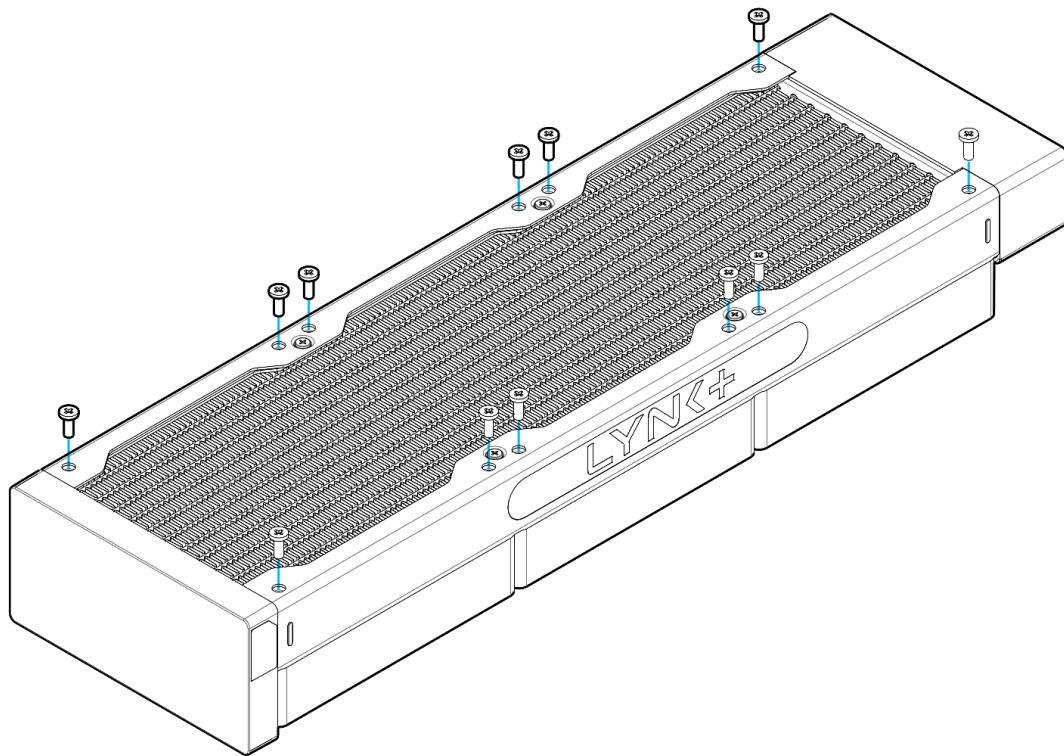

The LYNK+ system allows for the Radiator Module to be installed in any orientation, choose the one that best fits your PC case and mount the radiator using the provided PC case screws.

STEP 17: CONNECT RADIATOR CABLES

Connect SATA connector from power supply to radiator connector and connect radiator and cooler A-RGB cable to motherboard 3-in A-RGB header.

CONNECT BOTH MODULES USING THE LYNK+ QUICK CONNECT

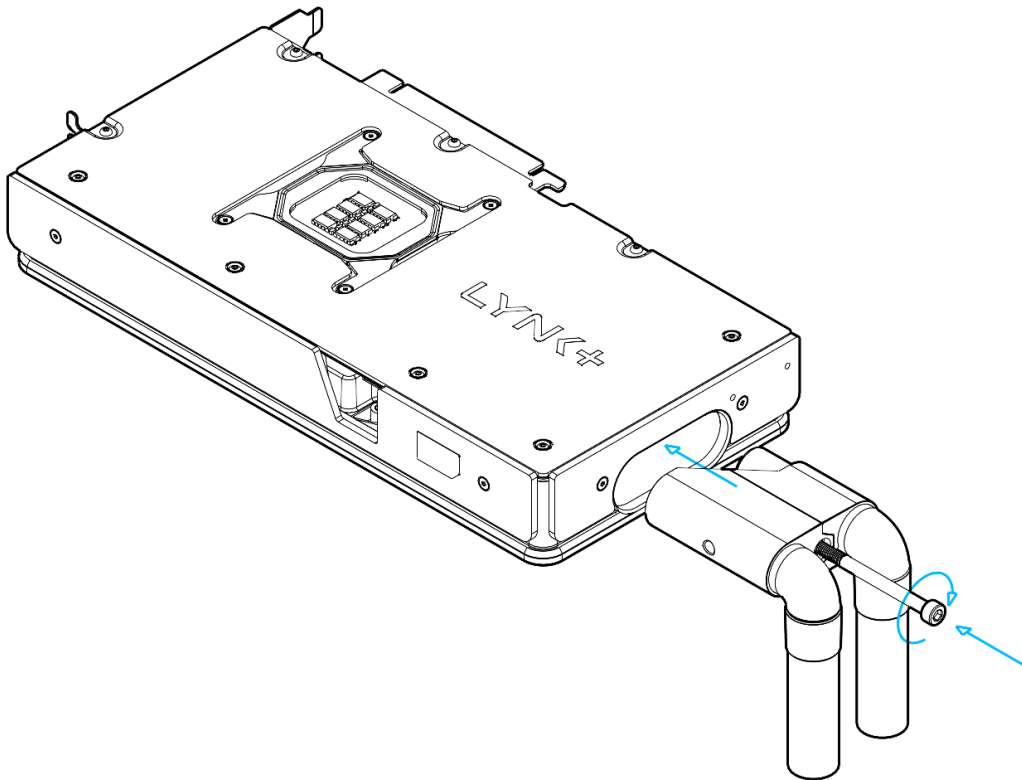

STEP 18

Insert Quick Connect in the direction shown, then insert screw, push lightly and fasten the screw using the provided Hex Key. Screw in until you feel a hard stop and the Quick Connect is flush with the cooler front.

The Quick Connect stays watertight all the way through the coupling process, there's no need to further tighten the screw after it stops.

INSTALLING LYNK+ GPU

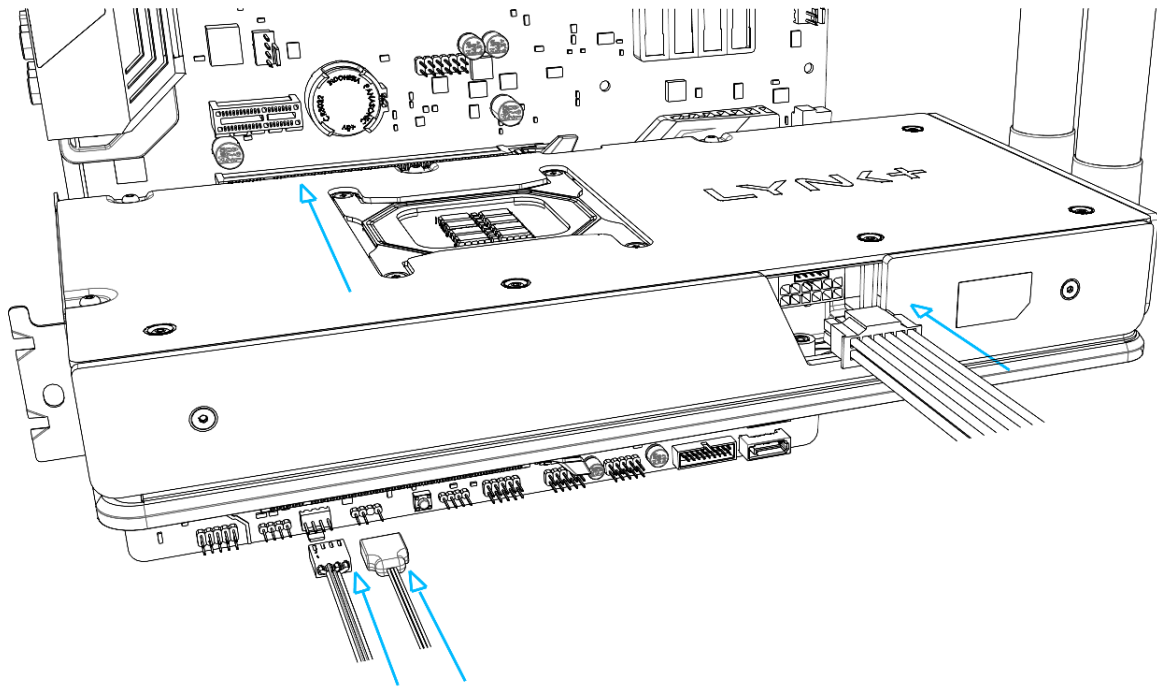

STEP 19: INSTALL GRAPHICS CARD

Insert the assembled graphics card into the PCI-Express slot of your mainboard.

Carefully plug the 16-pin 12VHPWR connector according to the instructions provided by the Graphics Card manufacturer, make sure the connector is fully inserted before starting the system.

Attach the D-RGB LED's 3-pin connector to a D-RGB header on your mainboard.

Attach the 4-pin FAN connector to a FAN header on your mainboard.

STEP 20: MAKE SURE EVERYTHING IS INSTALLED CORRECTLY

Check that all cables are connected correctly

Make sure Quick Connect is screwed in completely

Make sure the tubing has no kinks

YOU ARE NOW READY TO POWER ON YOUR SYSTEM

CONFIGURING THE FANS

ONCE THE SYSTEM IS RUNNING, CHECK STATUS LED ON THE FRONT OF RADIATOR MODULE, IF THE LED IS BLINKING, PLEASE REFER TO THE BLINK CODE IN THE TROUBLE SHOOTING SECTION FURTHER DOWN.

We highly recommend for the LYNK+ fans to be controlled **based on the temperature of your GPU**. There's more than one way of achieving this, here are our recommendations:

OPTION 1: FAN CONTROL SOFTWARE

Fan Control is a third party software for controlling fans **independent of what Mainboard brand** you built your system around. This software allows you to **control fans** based on any given system temperature, including **GPU temperature**. This is the software that we use for our in-house testing, and we highly recommend it:

1. Download and install the latest version of the Fan Control software at: <https://getfancontrol.com/>
2. Install all required updates, plugins or libraries when prompted on the first start.
3. Run the Assisted Setup, fan control will detect connected fans and help you pair the fan RPM Control to their corresponding speed sensors. Enable "Start at user log on" and "Start minimized".

- Once the connected fans and speeds are paired, select "Import from Configuration" from the three-dot menu on the right.



- Laden Sie die vorkonfigurierte Kurve, die Ihrem Anwendungsfall am besten entspricht, über [diesen Link](#) herunter. Wählen Sie im Importfenster die heruntergeladene .json-Konfigurationsdatei aus.

Name	Änderungsdatum	Typ	Größe
CACHE.json	20.11.2025 15:26	JSON-Datei	9 KB
LYNK+ 1800-2000 max. RPM Fans - Normal Mode1.json	20.11.2025 15:24	JSON-Datei	10 KB

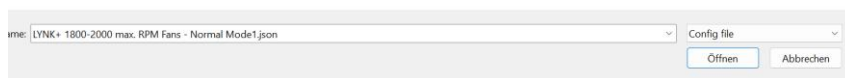

- Klicken Sie auf die Schaltfläche „Importieren“. Die vorkonfigurierte Lüfterkurve sollte nun unter „Kurven“ erscheinen. Wählen Sie die importierte Lüfterkurve

für die Drehzahlregelung Ihres LYNK+ Systems aus.



7. Sie sollten nun alles korrekt eingerichtet haben – viel Spaß!

WENN SIE BEI DER KONFIGURATION DER LÜFTERGESCHWINDIGKEIT AUF PROBLEME STOSSEN, STELLEN SIE SICHER, DASS DER LÜFTER-HEADER IN IHREM MAINBOARD-BIOS AUF PWM-LÜFTER EINGESTELLT IST.

OPTION 2: ASUS FANXPRT

Falls Sie ein aktuelles **ASUS-Mainboard** besitzen, beinhaltet die **ASUS Armoury Crate Suite** ein Modul zur Lüftersteuerung namens **FanXpert**. Diese Software ermöglicht es Ihnen, Lüfter basierend auf beliebigen Systemtemperaturen zu regeln, einschließlich der GPU-Temperatur:

1. Laden Sie die neueste Version der ASUS Armoury Crate von der folgenden Adresse herunter und installieren Sie sie: <https://armoury-crate.com/>
2. Installieren Sie das Assistant-Modul, welches das FanXpert-Modul beinhaltet, und führen Sie gegebenenfalls erforderliche Updates durch.
3. Notieren Sie sich den Namen des Lüfter-Headers, in den Sie das Kühlermodul auf Ihrem Mainboard eingesteckt haben.
4. Wählen Sie im Fenster von Fan Xpert aus der Lüfterliste den korrekten Chassis-Lüfter aus.

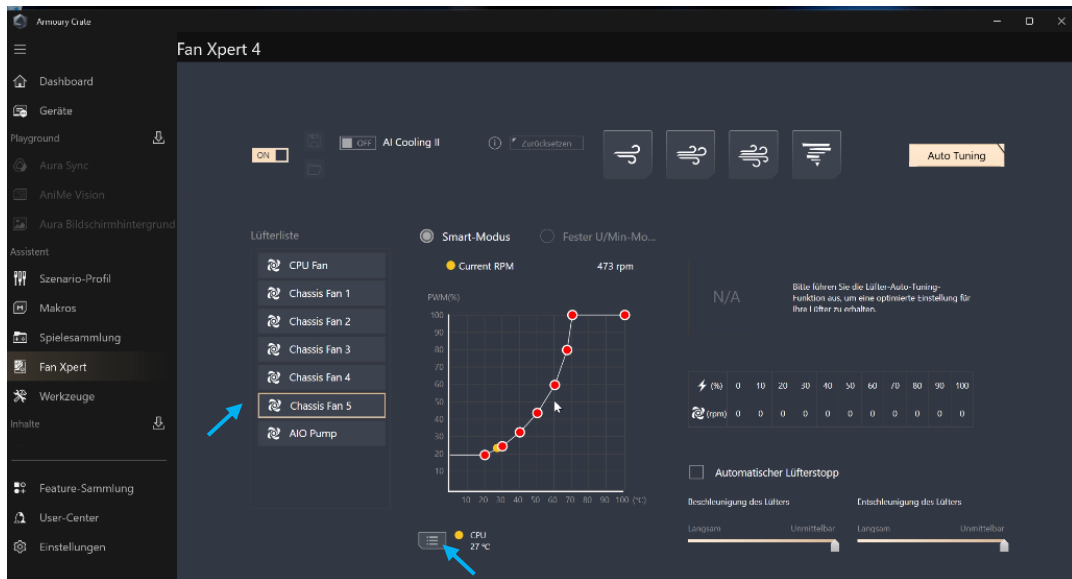

5. Konfigurieren Sie die Lüfter-Drehzahlkurve so, dass sie über die GPU-Temperatur gesteuert wird, und deaktivieren Sie die CPU-

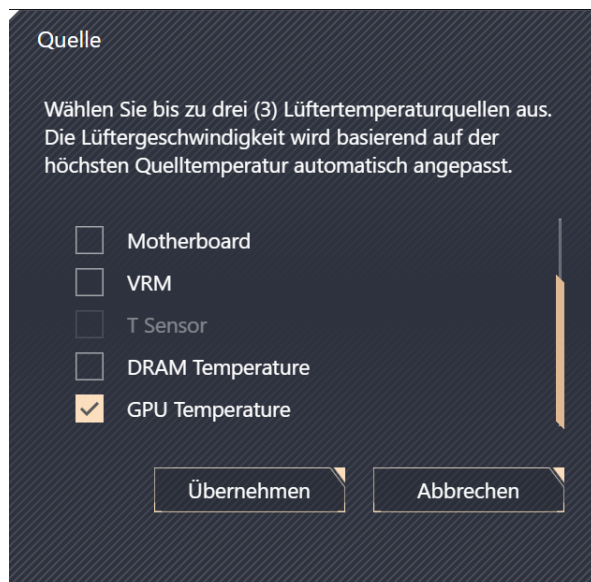

Temperatursteuerung.

6. Hier ist eine empfohlene Lüfterkurve für Lüfter mit einer maximalen Drehzahl zwischen 1800 und 2000 U/min. Falls Sie am Radiator schnellere oder langsamere Lüfter verbaut haben, passen Sie die Kurvenpunkte entsprechend an.

ON OFF AI Cooling II Zurücksetzen Auto Tuning

Lüfterliste

- CPU Fan
- Chassis Fan 1
- Chassis Fan 2
- Chassis Fan 3
- Chassis Fan 4
- Chassis Fan 5
- AIO Pump

Smart-Modus Fester U/Min-Mo...

Current RPM 208 rpm

GPU Tempera... 27 °C

Temperature (°C)	Current RPM
20	238
30	535
40	737
50	920
60	1095
70	1252
80	1406
90	1618
100	1746

Maximalgeschwindigkeit: 1746 (RPM)
 Mindestgeschwindigkeit: 238 (RPM)
 Regelbarer Bereich: 0% - 100%

(%)	0	10	20	30	40	50	60	70	80	90	100
(rpm)	238	535	737	920	1095	1252	1406	1618	1746	1746	1746

Automatischer Lüfterstopp

Beschleunigung des Lüfters Entschleunigung des Lüfters

Langsam Unmittelbar Langsam Unmittelbar

TROUBLESHOOTING & LED BLINK CODES

NORMALBETRIEB (STATUS-LED LEUCHTET KONSTANT):

Die Status-LED blinkt in den ersten 1-2 Sekunden nach dem Einschalten des Systems und leuchtet anschließend kontinuierlich.

BUS-SUCHE (STATUS-LED BLINKT LANGSAM, 1HZ) ODER BUS-FEHLER (STATUS-LED BLINKT 2X, 1HZ):

Der Bus wurde nicht verifiziert oder ist unterbrochen. Dieser Status gilt auch für die anfängliche Bus-Verifizierung. Die Pumpe läuft weiterhin mit 3900 U/min, die Lüfter drehen mit 1200 U/min, aber Lüfter- und Pumpengeschwindigkeit können nicht gesteuert werden. Stellen Sie sicher, dass die Kupplung bis zum Anschlag eingeschraubt ist, und überprüfen Sie, ob der 4-polige Lüfteranschluss korrekt verbunden ist und der "Lüftersteuerungsmodus" für diesen Anschluss in Ihrem BIOS oder Ihrer Mainboard-Steuerungssoftware auf "PWM" eingestellt ist.

PUMPENFEHLER (STATUS-LED BLINKT SCHNELL, 2HZ):

Das Pumpen-Drehzahlsignal ist zu niedrig oder zu hoch. Der Fehlerstatus wird aufgehoben, sobald der Drehzahlwert der Pumpe wieder normal ist. Dies kann bedeuten, dass sich Luft in der Pumpe gesammelt hat – in der Regel behebt ein Neustart das Problem. Falls nicht, versuchen Sie, den Radiator während des Starts leicht zu kippen, damit die Luft in den Ausgleichsbehälter entweichen kann.

KEINE STROMVERSORGUNG (STATUS-LED LEUCHTET NICHT):

Überprüfen Sie, ob das SATA-Kabel des Radiators mit der Stromversorgung verbunden ist.



Customer Support: support@lynk.plus

© 2025 TechN GmbH
All rights reserved. LYNK+ is a registered trademark.
Product may vary slightly from those pictured. 9500-5262-50-01